

Model: HIT-2A-MIL

*Hoffer Intelligent
Rate Indicator & Totalizer*

USER'S MANUAL



HP-326

November 2016

HOFFER
Flow Controls

Perfecting Measurement™

107 Kitty Hawk Lane • P.O. Box 2145 • Elizabeth City, NC 27909
1-800-628-4584 • (252) 331-1997 • Fax (252) 331-2886
www.hofferflow.com email: info@hofferflow.com

NOTICE

HOFFER FLOW CONTROLS, INC. makes no warranty of any kind with regard to this material, including, but not limited to, the implied warranties of merchantability and fitness for a particular purpose.

This manual has been provided as an aid in installing, connecting, calibrating, operating, and servicing this unit. Every precaution for accuracy has been taken in the preparation of this manual; however, HOFFER FLOW CONTROLS, INC. neither assumes responsibility for any omissions or errors that may appear nor assumes liability for any damages that may result from the use of the products in accordance with information contained in the manual.

HOFFER FLOW CONTROLS' policy is to provide a user manual for each item supplied. Therefore, all applicable user manuals should be examined before attempting to install or otherwise connect a number of related subsystems.

During installation, care must be taken to select the correct interconnecting wiring drawing. The choice of an incorrect connection drawing may result in damage to the system and/or one of the components.

Please review the complete model number of each item to be connected and locate the appropriate manual(s) and/or drawing(s). Identify all model numbers exactly before making any connections. A number of options and accessories may be added to the main instrument, which are not shown on the basic user wiring. Consult the appropriate option or accessory user manual before connecting it to the system. In many cases, a system wiring drawing is available and may be requested from HOFFER FLOW CONTROLS.

This document contains proprietary information, which is protected by copyright. All rights are reserved. No part of this document may be photocopied, reproduced, or translated to another language without the prior written consent of HOFFER FLOW CONTROLS, INC.

HOFFER FLOW CONTROLS' policy is to make running changes, not model changes, whenever an improvement is possible. This affords our customers the latest in technology and engineering. The information contained in this document is subject to change without notice.

Return Requests / Inquiries

Direct all warranty and repair requests/inquiries to the Hoffer Flow Controls Customer Service Department, telephone number (252) 331-1997 or 1-800-628-4584. BEFORE RETURNING ANY PRODUCT(S) TO HOFFER FLOW CONTROLS, PURCHASER MUST OBTAIN A RETURNED MATERIAL AUTHORIZATION (RMA) NUMBER FROM HOFFER FLOW CONTROLS' CUSTOMER SERVICE DEPARTMENT (IN ORDER TO AVOID PROCESSING DELAYS). The assigned RMA number should then be marked on the outside of the return package and on any correspondence.

FOR **WARRANTY** RETURNS, please have the following information available BEFORE contacting HOFFER FLOW CONTROLS:

1. P.O. number under which the product was PURCHASED,
2. Model and serial number of the product under warranty, and
3. Repair instructions and/or specific problems relative to the product.

FOR **NON-WARRANTY** REPAIRS OR CALIBRATIONS, consult HOFFER FLOW CONTROLS for current repair/ calibration charges. Have the following information available BEFORE contacting HOFFER FLOW CONTROLS:

1. P.O. number to cover the COST of the repair/calibration,
2. Model and serial number of the product and
3. Repair instructions and/or specific problems relative to the product.

LIMITED WARRANTY

HOFFER FLOW CONTROLS, INC. ("HFC") warrants HFC's products ("goods") described in the specifications incorporated in this manual to be free from defects in material and workmanship under normal use and service, but only if such goods have been properly selected for the service intended, properly installed and properly operated and maintained. This warranty shall extend for a period of one (1) year from the date of delivery to the original purchaser (or eighteen (18) months if the delivery to the original purchaser occurred outside the continental United States). This warranty is extended only to the original purchaser ("Purchaser"). *Purchaser's sole and exclusive remedy is the repair and/or replacement of nonconforming goods as provided in the following paragraphs.*

In the event Purchaser believes the goods are defective, the goods must be returned to HFC, transportation prepaid by Purchaser, within twelve (12) months after delivery of goods (or eighteen (18) months for goods delivered outside the continental United States) for inspection by HFC. If HFC's inspection determines that the workmanship or materials are defective, the goods will be either repaired or replaced, at HFC's sole determination, free of additional charge, and the goods will be returned, transportation paid by HFC, using the lowest cost transportation available.

Prior to returning the goods to HFC, Purchaser must obtain a Returned Material Authorization (RMA) Number from HFC's Customer Service Department within 30 days after discovery of a purported breach of warranty, but no later than the warranty period; otherwise, such claims shall be deemed waived. See the Return Requests/Inquiries Section of this manual.

If HFC's inspection reveals the goods are free of defects in material and workmanship or such inspection reveals the goods were improperly used, improperly installed, and/or improperly selected for service intended, HFC will notify the purchaser in writing and will deliver the goods back to Purchaser upon (i) receipt of Purchaser's written instructions and (ii) the cost of transportation. If Purchaser does not respond within thirty (30) days after notice from HFC, the goods will be disposed of in HFC's discretion.

HFC does not warrant these goods to meet the requirements of any safety code of any state, municipality, or other jurisdiction, and Purchaser assumes all risk and liability whatsoever resulting from the use thereof, whether used singly or in combination with other machines or apparatus.

This warranty shall not apply to any HFC goods or parts thereof, which have been repaired outside HFC's factory or altered in any way, or have been subject to misuse, negligence, or accident, or have not been operated in accordance with HFC's printed instructions or have been operated under conditions more severe than, or otherwise exceeding, those set forth in the specifications for such goods.

THIS WARRANTY IS EXPRESSLY IN LIEU OF ALL OTHER WARRANTIES, EXPRESSED OR IMPLIED, INCLUDING ANY IMPLIED WARRANTY OF MERCHANTABILITY OR FITNESS FOR A PARTICULAR PURPOSE. HFC SHALL NOT BE LIABLE FOR ANY LOSS OR DAMAGE RESULTING, DIRECTLY OR INDIRECTLY, FROM THE USE OR LOSS OF USE OF THE GOODS. WITHOUT LIMITING THE GENERALITY OF THE FOREGOING, THIS EXCLUSION FROM LIABILITY EMBRACES THE PURCHASER'S EXPENSES FOR DOWNTIME OR FOR MAKING UP DOWNTIME, DAMAGES FOR WHICH THE PURCHASER MAY BE LIABLE TO OTHER PERSONS, DAMAGES TO PROPERTY, AND INJURY TO OR DEATH OF ANY PERSONS. HFC NEITHER ASSUMES NOR AUTHORIZES ANY PERSON TO ASSUME FOR IT ANY OTHER LIABILITY IN CONNECTION WITH THE SALE OR USE OF HFC'S GOODS, AND THERE ARE NO ORAL AGREEMENTS OR WARRANTIES COLLATERAL TO OR AFFECTING THE AGREEMENT. *PURCHASER'S SOLE AND EXCLUSIVE REMEDY IS THE REPAIR AND/OR REPLACEMENT OF NONCONFORMING GOODS AS PROVIDED IN THE PRECEDING PARAGRAPHS. HFC SHALL NOT BE LIABLE FOR ANY OTHER DAMAGES WHATSOEVER INCLUDING INDIRECT, INCIDENTAL, OR CONSEQUENTIAL DAMAGES.*

Disclaimer

Specifications are subject to change without notice.
Some pages are left intentionally blank.

CONTENTS

1. Introduction	1
Model Number Designation	2
2. SPECIFICATIONS	3
2-1 General	3
2-2 Inputs	3
2-3 Battery Powered Version	4
2-4 DC Power/Loop Powered	4
2-5 AC Power	4
2-6 Analog (4-20mA) Output Option	4
2-7 Pulse Output Option	5
2-8 Alarm Output Option	5
2-9 Physical	5
3. Theory of Operation	7
3-1 Functional Blocks	7
3-1-1 User Interface	7
3-1-2 Preamplifier	7
3-1-3 Microcontroller	7
3-1-4 Loop Driver	8
3-1-5 Pulse and Alarm Output	8
3-1-6 Communications Interface	9
3-2 System Response Time	9
4. Installation	11
4-1 Typical Input Connections	11
4-2 Typical Output Connections	14
4-3 Communications Connections	17
4-4 Wiring	17
4-5 Terminal Designations	17
5. Configuration	19
5-1 Local Configuration	19
5-2 Default Configuration	22
5-3 Remote Configuration	22
6. Operation and Maintenance	23
6-1 Operation	23
6-2 Maintenance	24
6-3 Error Messages	24
6-4 Analog Output Calibration	25

7. Assembly/Disassembly Procedure	27
8. Recommended Spare Parts List	29
Appendix A – Default Configuration	30
Appendix B - Communications	32
Message Format And Timeout	32
Messages	34

1. INTRODUCTION

The HIT-2A-MIL is a microprocessor-based flow rate indicator and totalizer. The instrument displays flowrate and a resettable total and is compatible with all Hoffer turbine flowmeters and the H.O.G. series positive displacement flowmeters.

The instrument can accept a low level frequency signal, a pulse signal, or a contact closure on the input and provides a linearized rate indication and total.

The HIT-2A-MIL is fully configurable with K-factors, frequencies, and timebase being configured via the front panel key switches or the RS232 communications port. The configuration and monitoring can be performed using any PC based communications program (e.g., HyperTerminal) or ASCII terminal.

The instrument is housed in an attractive NEMA 4X polycarbonate enclosure and can be mounted directly on a flowmeter or wall mounted using an optional mounting brackets or an EX enclosure.

This instrument has been designed to conform to the EMC-Directive of the Council of European Communities 89/336/EEC and the following standards:

Generic Emission Standard EN 61000-6-3

Residential, Commercial & Light Industry Environment.

Generic Immunity Standard EN 61000-6-1

Residential, Commercial & Light Industry Environment.

Electrostatic discharge requirements EN 61000-4-2

Radiated, radio-frequency, electromagnetic immunity EN 61000-4-3

Electrical fast transient/burst requirements EN 61000-4-4

Immunity to conducted disturbances EN 61000-4-6

Model Number Designation

MODEL HIT-2A-MIL TOTALIZER/FLOW RATE INDICATOR

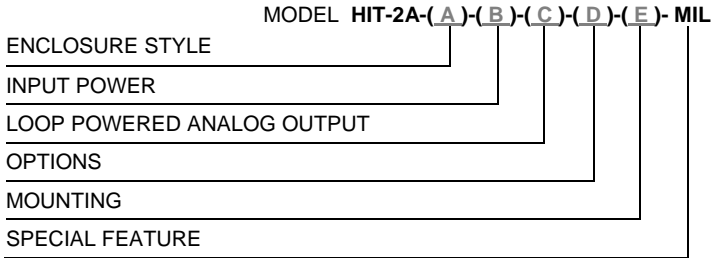

ENCLOSURE STYLE

MODEL HIT-2A-(A)-()-()-()-()-MIL

OPTION (A)

- (2) NEMA 4X ENCLOSURE, HIT-2A-MIL MOUNTED BEHIND CLEAR COVER.
- (3) EXPLOSION-PROOF ENCLOSURE.
- (3A) ATEX Exd ENCLOSURE, STANDARD BLUE
- (3B) ENCLOSURE FOR BRAZIL, GRAY
- (P) PANEL MOUNT - SURFACE MOUNTED ON CUSTOMER'S PANEL;
NO ENCLOSURE BEHIND PANEL ON HIT-2A-MIL.
- (PD) PANEL MOUNT ENCLOSURE WITH CLEAR DOOR AND LOCK
- (4) NEMA 1 ENCLOSURE (HIT-2A-MIL MOUNTED TO THE OUTSIDE OF CLEAR
COVER FOR INDOOR/DRY INSTALLATION ONLY)
- (5) NEMA 4X ENCLOSURE/HIT2A ENCLOSURE (MOUNTED BEHIND CLEAR COVER
WITH SUNSHADE.)

INPUT POWER

MODEL HIT-2A-()-(B)-()-()-()-MIL

OPTION (B)

- (A) INTERNAL BATTERIES (TWO EACH).
THIS OPTION CAN NOT SUPPORT REDI-PULSE COILS.
- (B) 8 TO 30 VDC EXTERNAL POWER.
- (AC) UNIVERSAL 100-240 VAC @ 0.15A 50/60 HZ.
- (X) ENTER (X) IF LOOP POWERED ANALOG OUTPUT OPTION
(C) OR (D) BELOW IS SELECTED.

LOOP POWERED ANALOG OUTPUT

MODEL HIT-2A-()-()-(C)-()-()-MIL

OPTION (C)

- (C) LOOP POWERED 4-20MA OUTPUT (8 TO 30 VDC)
- (D) LOOP POWERED 4-20MA OUTPUT WITH INTERNAL BATTERIES

OPTIONS**MODEL HIT-2A-()-()-()-(D)-()- MIL****OPTION (D)**

- (L) 20 POINT LINEARIZATION.
- (RR) REMOTE RESET
- (AL) LOW ALARM* OPTO ISOLATED OPEN COLLECTOR.
- (AH) HIGH ALARM* OPTO ISOLATED OPEN COLLECTOR.
- (HT) HEATER; REQUIRES DC POWER INPUT OPTION.

*NOTE: EITHER LOW OR HIGH ALARM IS AVAILABLE, NOT BOTH.

MOUNTING**MODEL HIT-2A-()-()-()-()-(E)- MIL****OPTION (E)**

- (F) NEMA 4X STYLE 2 ENCLOSURE MOUNTED ON TURBINE. MUST BE USED WITH "X" RISER TURBINE OPTION.
- (FHT) 8" LONG TEMPERATURE RISER FOR NEMA 4X STYLE 2 ENCLOSURE MOUNTED ON TURBINE. REQUIRED WHEN FLUID TEMPERATURES EXCEED 140 DEG. F. USED WITH "X" RISER TURBINE OPTION.
- (FX) EXPLOSION-PROOF STYLE 3 ENCLOSURES MOUNTED ON TURBINE. MUST BE USED WITH "X" RISER TURBINE OPTION.
- (FXHT) 8" LONG TEMPERATURE RISER FOR EXPLOSION-PROOF STYLE 3 ENCLOSURES MOUNTED ON TURBINE. REQUIRED WHEN TEMPERATURES EXCEEDS 140 DEG. F. USED WITH "X" RISER TURBINE OPTION.
- (NP) ENCLOSURE PIPE MOUNTING KIT, 2" PIPE OR SMALLER. SPECIFY IF PIPE IS VERTICAL OR HORIZONTAL.

SPECIAL FEATURES**MODEL HIT-2A-()-()-()-()-()- MIL****OPTION (F)**

- (MIL) MIL-S-901D, "SHOCK TESTS, H.I. (HIGH IMPACT) SHIPBOARD MACHINERY, EQUIPMENT, AND SYSTEMS, REQUIREMENTS FOR;" DATED 17 MARCH 1989. MIL-STD-167-1, MECHANICAL VIBRATION OF SHIPBOARD EQUIPMENT (TYPE I - ENVIRONMENTAL & TYPE II - INTERNALLY EXCITED), 1 MAY 1974.
- (X) NO SPECIAL FEATURES

- NOTES: 1. OPTO-ISOLATED OPEN COLLECTOR TRANSISTOR IS STANDARD WITH ALL UNITS.
2. A LOCAL RESET MAGNET IS STANDARD WITH ALL UNITS EXCEPT IF REMOTE RESETOPTION IS SELECTED.
3. WINDOWS® BASED SETUP DISC AND, IF REQUIRED, 6 FT COMMUNICATION CABLE. IF THREE OR MORE UNITS ARE ORDERED ON THE SAME PURCHASE ORDER ONE SET IS SUPPLIED AT NO CHARGE.

SPARE BATTERIES:

MODEL ER26500M OR EQUIVALENT; LITHIUM SIZE C, 3.6V 6000 mAh (TWO BATTERIES ARE REQUIRED FOR BATTERY POWERED UNITS. ONE BATTERY IS REQUIRED FOR ALL OTHER POWER OPTIONS TO RETAIN TOTAL DISPLAY IF POWER FAILS.

This page intentionally left blank.

2. SPECIFICATIONS

2-1 General

Display:	LCD, continuously powered
Total:	8 digits 0.26" high. Resettable from front panel.
Total Units:	GAL, LIT, FT3, M3, BBL, & "blank".
Rate:	5 digits 0.5" high.
Rate Units:	/MIN, /HR, & /DAY
K-factor:	The pulses per unit of Total (e.g. pulses/gallon) are configurable in the range 0.001 to 99,999,999.
Linearization:	Up to 20 points.
Decimal Points:	Decimal Point positions are fully configurable for both rate and total.
Accuracy:	± 1 count
Temperature drift:	50 ppm/ $^{\circ}$ C

2-2 Inputs

Magnetic Pickup:

Frequency Range:	0.2 Hz to 5000 Hz.
Signal Type:	Low-level sinusoidal (30 mV P-P minimum).

Opto-Isolated DC Pulse:

Frequency Range:	0 Hz to 3000 Hz.
Signal Type:	DC pulse.
High (Logic 1):	4 to 30 VDC
Low (Logic 0):	< 1 VDC
Min Current:	0.5 mA
Hysteresis:	0.4 VDC
Min Pulse width:	0.1 msec

Contact Closure:

Frequency Range:	0 Hz to 5000 Hz
Signal Type:	Contact closure to DC common
High (Logic 1):	Open or 4 to 30 VDC
Low (Logic 0):	< 0.5 VDC
Internal Pull-up:	220 k Ω to +3.3 VDC

Reset:

Signal Type:	Contact closure to DC common
High (Logic 1):	4 to 30 VDC
Low (Logic 0):	< 0.5 VDC
Min Current:	0.5 mA
Min On:	25 msec
Internal Pull-up:	100 k Ω to +3.3 VDC
External Magnet:	Activates internal reed switch

2-3 Battery Powered Version

Type:	Two C-size lithium battery packs.
Battery Life:	4 years typical*
	10 years typical* for external power.

* With the pulse output OFF. With pulse output ON 30% less.

2-4 DC Power/Loop Powered

Voltage:	8 to 30 VDC
Current:	< 4 mA
Loop Burden:	8 VDC maximum
Supply Backup:	One (1) C-size Lithium battery
Protection:	Reverse polarity protected

2-5 AC Power

Voltage:	100 to 240 VAC
Frequency:	47 – 440 Hz
Current:	150 mA
Line Regulation:	$\pm 0.3\%$, typ
Protection:	Short circuit, Over voltage, & Over temperature
Supply Backup:	One (1) C-size Lithium battery

2-6 Analog (4-20mA) Output Option

Scale:	4 – 20 mA follows rate.
Accuracy:	0.02% of Full Scale @ 20°C.
Temperature drift:	40 ppm/°C
Update Time:	2.0 seconds.
Connection:	Two wire.
Protection:	Reverse polarity protected

2-7 Pulse Output Option

Type: Opto-isolated open collector (100 VDC, 100 mA).
 Divider: 1, 10, 100, or OFF
 Rate & Duration: See below.

SPEED (Hz)	1	2	4	8
Min on/off (msec)	500	250	125	62.5

2-8 Alarm Output Option

Type: Opto-isolated open collector (100 VDC, 100 mA).
 Function: Rate or Total

2-9 Physical

Temperature: Operating: -40°F (-40°C) to 158 °F (70°C)
 -58°F (-50°C) with optional heater.
 32°F (0°C) to 140 °F (60°C) with AC power option.

Humidity: 0 – 90% Non-condensing.

Packaging: Wall Mount & Explosion proof

Dimensions for Wall Mount enclosure: 4.33" (110 mm) wide x 4.33" (110 mm) long
 4.33" (110 mm) tall.

This page intentionally left blank.

3. THEORY OF OPERATION

The HIT-2A-MIL consists of six functional blocks. These functional blocks are the User Interface, Preamplifier, Microcontroller, Loop Driver, Pulse and Alarm Output, and Communications Interface.

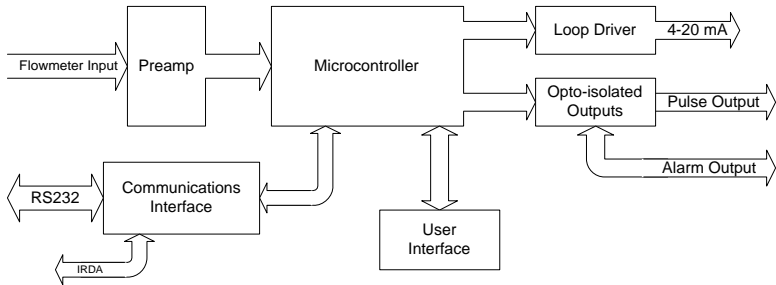

3-1 Functional Blocks

3-1-1 User Interface

The User Interface consists of a custom LCD display with 4 push buttons; OK, P, > (right arrow), and ^ (up arrow) and an optional external reset. Using the buttons and the displayed information, the user can enter setup parameters (rate units, pulses per unit of flow, etc.) as well as setup information for the pulse output and 4-20mA output. The optional external reset maybe used to reset the accumulated total to zero and clear the displayed accumulated total.

3-1-2 Preamplifier

The Preamplifier accepts the input from the flowmeter. The Preamplifier applies amplification, low-pass filtering, and wave-shaping to the input signal. The wave shaping function converts the signal into a square-wave before sending it to the Microcontroller.

3-1-3 Microcontroller

The Microcontroller accepts the square-wave output of the preamplifier and performs all of the calculations that are required to control the Loop Driver. After measuring the frequency of the

square-wave, the Microcontroller uses the following equations to compute the flow rate and current.

$$\text{flowrate} = \frac{\text{frequency}}{\text{Kfactor}} \times 60^{FM} \times CF$$

Where:

- Kfactor = Is dependent on the Flow Calculation Method setting and is either the Average K-Factor or the Linearized K-Factor from the Frequency / K-Factor table.
- FM = Is the Flow rate Units setting of 0, 1, 2 or 3. Where “0” is for Seconds, “1” is for Minutes, “2” is for Hours and “3” is for days.
- CF = Is the Correction Factor setting.

$$\text{current} = 4\text{mA} + \left(16\text{mA} \times \frac{\text{flowrate}}{\text{AF}} \right)$$

Where:

- AF = is the 20 mA maximum Flow Rate value.

If the calculated flowrate is greater than the AF setting, the current will be set to 24mA to signal an “Over-range” condition. After calculating the current, the Microcontroller digitally sends the current information to the Loop Driver.

3-1-4 Loop Driver

The loop driver uses the digital information received from the Microcontroller to set the current of the loop. The Loop Driver supplies power to both the Preamplifier and Microcontroller.

3-1-5 Pulse and Alarm Output

The Pulse and Alarm outputs are two optically isolated open collector outputs. The alarm output activates when the total flow or the rate reaches a user defined level. The pulse output activates to give a scaled pulse output indicative of the total flow. Both of these outputs are rated for 100 VDC at 100 mA.

3-1-6 Communications Interface

The communication is provided through a RS232C interface to the Microcontroller. The external terminal device provides the power for the RS232 interface. The Communications Interface is used to configure and trouble-shoot the device.

3-1-7 Clearing Total

The Total amount stored in HIT-2A-MIL memory can be cleared from the front panel program menu, by external momentary switch wired to the reset input, or by external magnet. The magnet has to be brought close to top of the front panel.

3-2 System Response Time

The displayed Rate and Total are updated every two (2) seconds. The analog output response time to reach steady state due to a change in the flow rate is also approximately two (2) seconds. When flow stops, the time for the analog output to return to 4 mA will be between 3 and 12 seconds, depending on the Maximum Sample Time (MST) setting. MST is adjusted using the NB= (DATA) command, where NB is a value between 1 and 80. The default MST setting is NB= 1. Adjusting the MST is only recommended for low flow applications where the minimum input frequency is below 1 Hz.

This page intentionally left blank.

4. INSTALLATION

The HIT-2A-MIL has an input conditioning circuit, which accepts signals from most frequency or pulse producing flowmeters.

The input will interface directly to:

- Turbine Flowmeters
- Reed Switches
- Logic Signals
- Open Collector Outputs

The input is protected for over voltage up to 50 volts.

The flowmeter input (terminals 1 & 2) must be configured for the selected signal type by appropriately setting the input selection jumpers found on the HIT-2A-MIL signal input board (see following for jumper positions).

4-1 Typical Input Connections

MAG Coil & Reed Switch Pickups

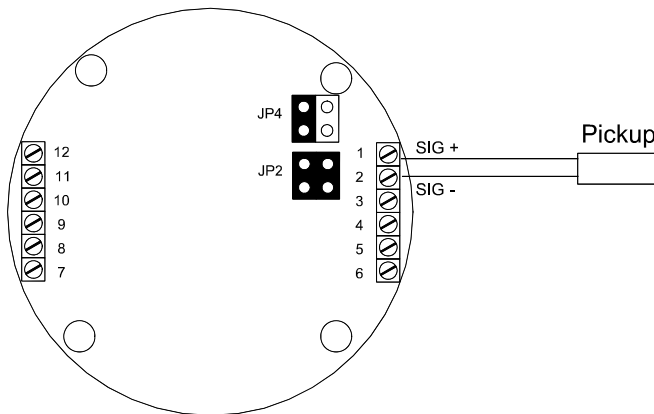

TTL Redi-Pulse Pick-up with DC Power

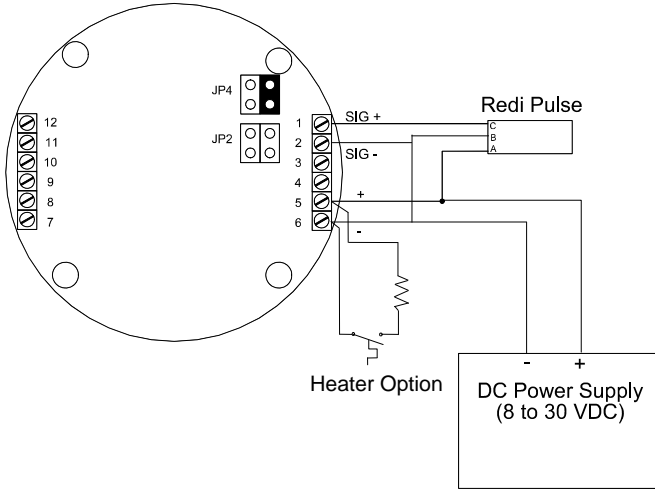

Reset Input

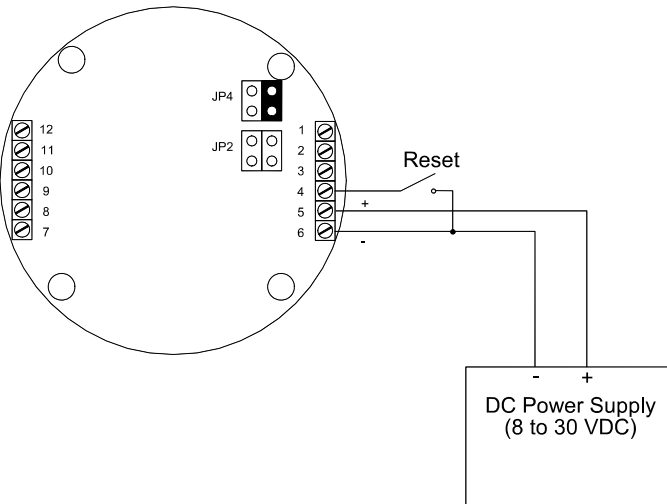

Loop Power with TTL Redi-Pulse

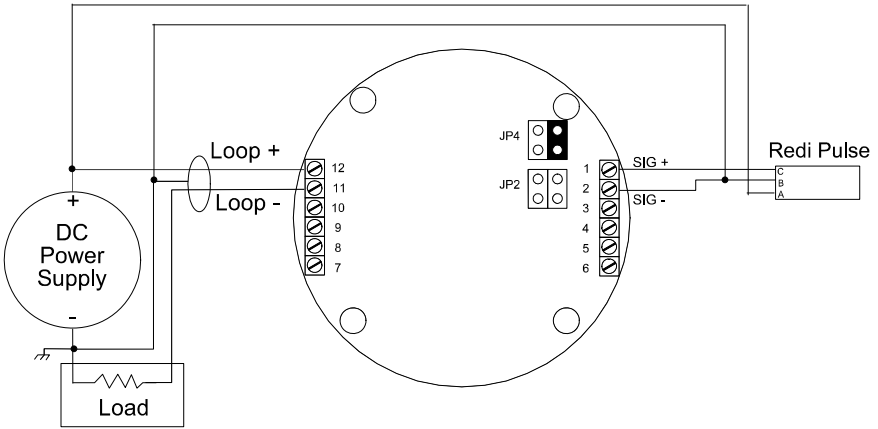

Loop Power with Redi-Pulse Open Collector Output

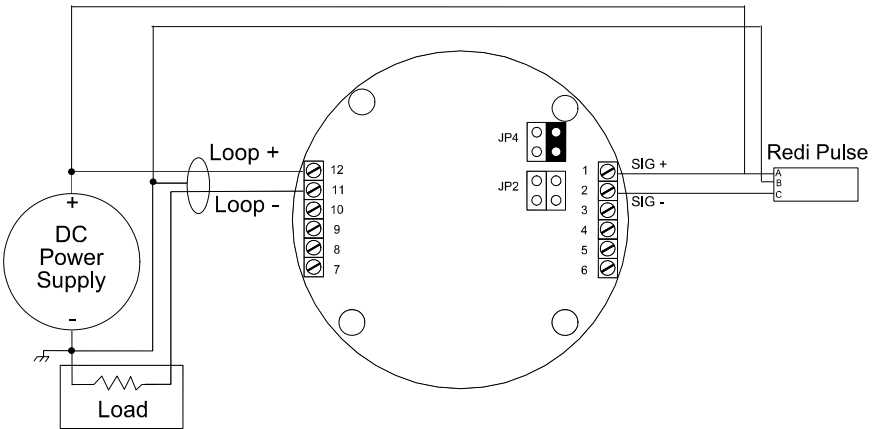

TTL Redi-Pulse with AC Power

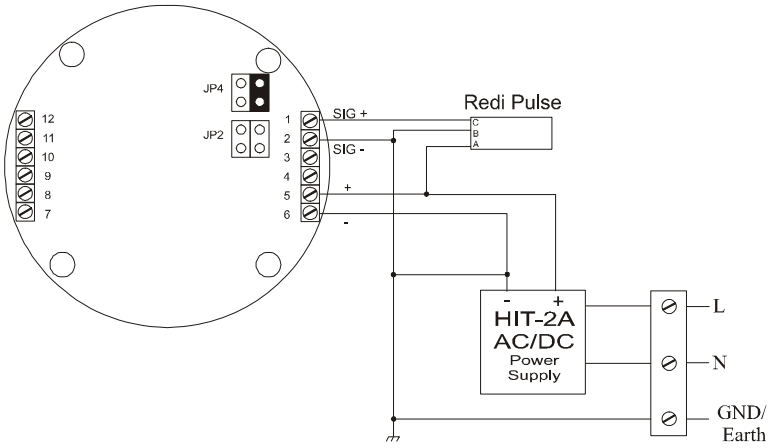

4-2 Typical Output Connections

Analog Output with DC Power

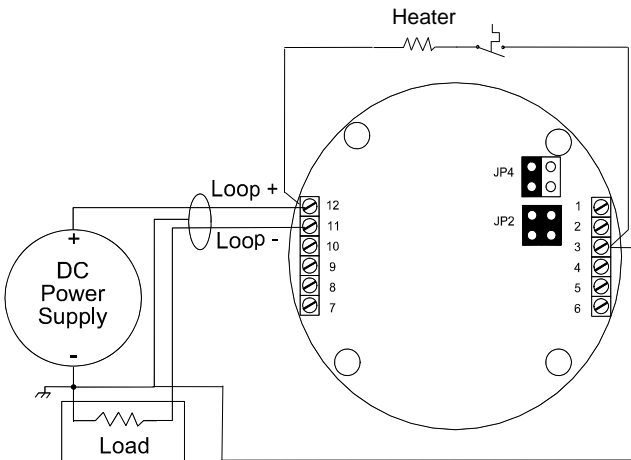

Analog Output with AC Power

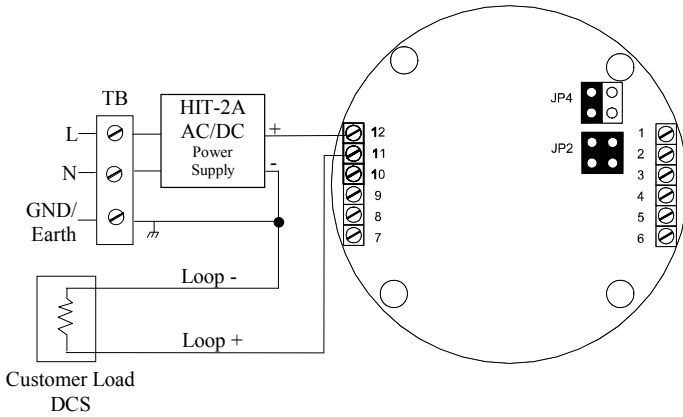

Alarm Output

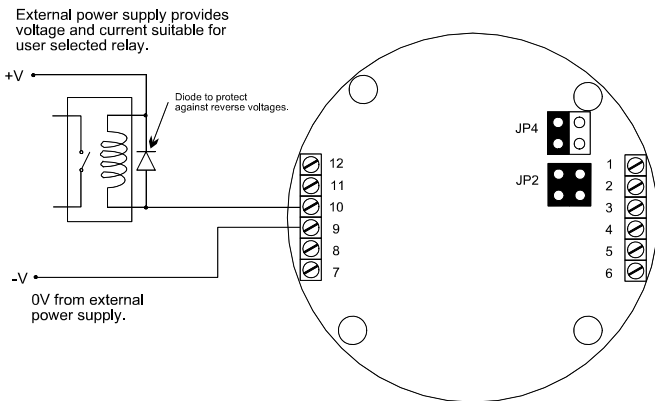

Analog Output and TTL Redi-pulse with AC Power

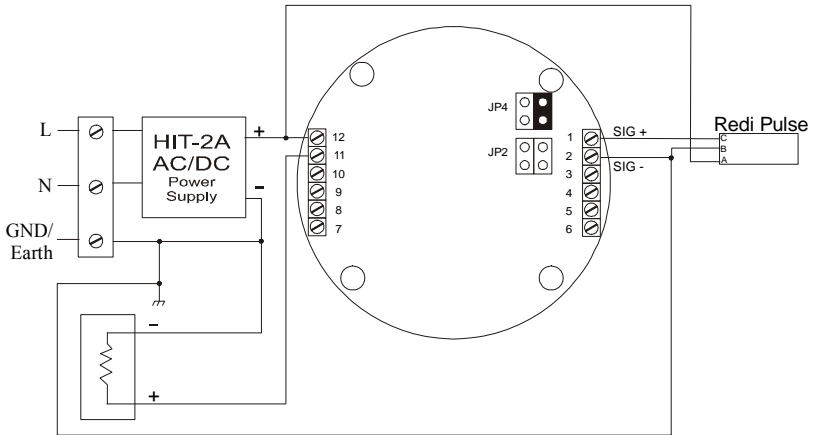

Pulse Output

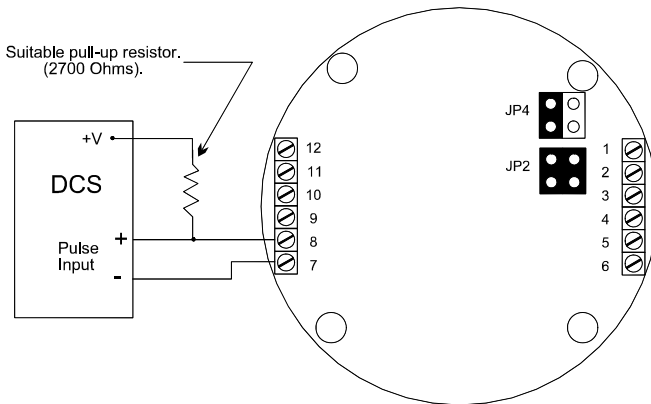

4-3 Communications Connections

Communications with the HIT-2A-MIL using a terminal or a PC using the Windows configuration program requires the use of the HOFFER HIT2A-301 Communications Cable. The communication circuits of the HIT-2A-MIL are externally powered and the power for these circuits is supplied by the RS232 serial port of the computer/terminal. The serial port configuration must be set to the following:

Baud rate: 2400
 Data bits: 8
 Parity: none
 Stop bits: 1
 Handshaking: None

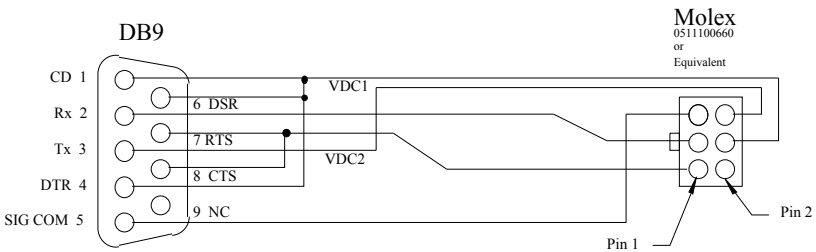

Hoffer HIT2A-301 Communications Cable

4-4 Wiring

When connecting the HIT-2A-MIL, it is good practice to use shielded cable. The shield should be connected to earth ground near the instrument. The other end of the shield should not be connected.

In order to comply with the requirements for Electromagnetic Compatibility, as per EMC-Directive 89/336/EEC of the Council of European Community, this wiring practice is mandatory.

4-5 Terminal Designations

Terminal	Description
1	Signal/Pulse Input (+)
2	Signal/Pulse Input (-)
3	Shield
4	Reset Input
5	VDC (+)
6	VDC (-) / Reset Common
7	Pulse out (-)
8	Pulse out (+)
9	Alarm (-)
10	Alarm (+)
11	4-20 mA (-)
12	4-20 mA (+)

This page intentionally left blank.

5. CONFIGURATION

The HIT-2A-MIL is fully configurable, with all parameters being stored in non-volatile memory.

The instrument may be configured using the front panel keys, a PC running Terminal Emulation software, a ASCII terminal, or a PC running the HIT-2A-MIL Configuration software.

5-1 Local Configuration

Local configuration is accomplished using the four buttons below the display while viewing the configuration parameters on the display.

The local configuration mode is entered by pressing the **P** button.

Once in the local configuration mode each of the four buttons have a special purpose as detailed below.

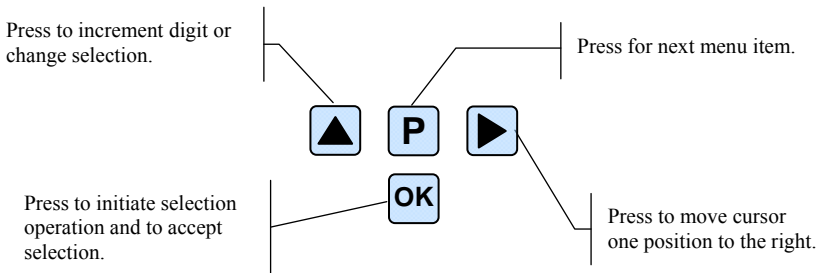

<i>Display</i>	<i>Option</i>	<i>Menu item Description</i>
CLEAR tot no	Yes No	Clear Total Clears accumulated total and sets TOTAL display to zero.
:0000000 tR9		Tag Number User defined 5-digit number. (#####)
Ave-RSE FAC nn	Linear Average	Linearization Method Sets the flow calculation method to average K-factor or K-factor table.
00000.000 FAC d		K-factor Decimal Point Set K-factor decimal point location.
:.000 A FAC		Average K-factor Enter average K-factor.
Points 20	2 to 20	Number of Points Sets the number of entries in the linearization table.
4999.98: Fr 0:	0 to 5000	Frequency 1-20 Enter a frequency in Hz for each entry in the table. Decimal point is fixed.
:.000 FAC0:		K-factor 1-20 Enter a k-factor in pulses/gal for each entry in the table.
:.000 C FAC	0.001 to 99999.999	Correction Factor User defined number between 0.001 and 99999.999 to multiply flow and total. Default 1.0.
tot unit :00	100 = GAL 110 = FT3 140 = LIT 150 = M3 180 = BBL	Total Units Select Total units. If custom is selected all indicators are off. (gal, lit, ft3, m3, bbl, custom)
0000000.0 tot d		Total Decimal Point Set Total decimal point location.

<i>Display</i>	<i>Option</i>	<i>Menu item Description</i>
FL U AN IN	SEC Min HrS dAY	Rate Units Select RATE units.
00000.000 FL d		Rate Decimal Point location Set Rate decimal point location.
SRPLE :	1 to 80	Max Sample Time Set maximum time in seconds to sample the input frequency. Default 1.
:000 outLo		Out Low Sets flow rate value for 4 mA output.
99.999 outHi		Out High Sets flow rate value for 20 mA output.
PULSE S OFF	oFF 1 10 100	Pulse Scale Sets scale for pulse out. 1, 10, 100 units of total for one pulse out. OFF- turns pulse out off.
PULSE F 8	1 2 4 8	Pulse Frequency Sets frequency of burst of pulse out. (1, 2, 4, 8)
PASS 1234	0000 to 9999	Password Sets 4-digit password. Default 0000.
unit Loc no	Yes No	Lock Unit Locks the unit.
ALARn OFF	oFF rAtE tot	Alarm Function Select Rate or Total for alarm output. OFF- turns alarm function off.
:00000.0 ALARn		Alarm Out Sets value to activate the alarm output. Default 99999.999

<i>Display</i>	<i>Option</i>	<i>Menu item</i> <i>Description</i>
0.0 Set t		Set Total Sets Total to user defined value.
Cur out rAtE	rAtE 4 12 20	Current Out Sets analog output to follow rate or predefined level.
Pul tEst no	Yes No	Pulse Output Test Outputs a test frequency of 1Hz, 50% duty cycle.
Al tEst no	Yes No	Alarm Output Test Activates alarm output.

5-2 Default Configuration

The HIT-2A-MIL is configured by the factory before shipment. When the instrument is purchased with a Hoffer Flowmeter or when calibration and configuration data are supplied, the instrument is configured as specified. When the instrument is shipped without specific configuration information, the instrument is configured with default values. Refer to Appendix A for a listing of the HIT-2A-MIL factory default configuration.

5-3 Remote Configuration

The HIT-2A-MIL may be configured remotely via the RS232 communications interface. Refer to Appendix B for the communications details.

6. OPERATION AND MAINTENANCE

6-1 Operation

A suitable pulse producing device or flow meter is wired to the HIT-2A-MIL Signal Input terminals 1 (Sig +) and 2 (Sig -). The Signal Input circuit must be configured for the connected input device using the appropriate jumper blocks.

Internal batteries, external DC, or a loop current may provide power to the unit. For all power options other than internal batteries (A), if the primary power is lost, the internal backup battery will provide for continued operation of the totalizer.

Once properly wired, the operation of the HIT-2A-MIL is automatic.

The flow totalizer is updated every 2 seconds* with the latest total. If no input counts are received the unit remains in a low power state to conserve power.

The flow total may be cleared by the front panel switch sequence or by a contact closure on the remote reset terminal to circuit common.

To reset the unit from the front panel, the following key sequence is required:

Press P	CLEARtot is displayed
Press OK	To enter edit mode.
Press ▲	To select yes
Press OK	To clear total
Press ▲	To return to operating mode

The flow rate indicator measures the flow rate once every 2 seconds* and display the flow rate.

If the input pulses are not detected within the maximum sample time (1 to 80 seconds), a flow rate of zero (0.00) is indicated.

The analog output is scaled based on the user selected zero and full scale and the measured flow rate.

The pulse output generates a burst of pulses every 2 seconds* in accordance with the instrument setup of pulse scaling.

* A large sample time setting and internal math operations may delay the update rate.

6-2 Maintenance

The only scheduled maintenance for the HIT-2A-MIL is periodic battery replacement.

The instrument has a battery monitor feature which illuminates when the lithium battery voltage approaches its end of life. A descriptor, "LO BAT", illuminates when the battery voltage falls below this predetermined value. The low battery detector operates correctly with all power options.

The battery, or batteries, should be replaced within several weeks of the first occurrence of low battery warning. Left unattended, the unit may become inaccurate, cease to operate, lose setup information, or malfunction.

The batteries should be replaced one at a time to avoid interrupting the power.

6-3 Error Messages

The HIT-2A-MIL is provided with extensive self checking which is used in reporting malfunctions or unusual operating conditions. When an error occurs, the display will flash with an error message until the user presses the OK button acknowledging the error condition. Once an error condition is acknowledged, the error message will not be displayed again for 60 seconds if the cause of the error is still present.

If the alarm output is active from an alarm caused by a rate or total condition, depressing the **OK** button while the display is showing the rate and total will reset the alarm output if the condition that caused the alarm is no longer present. If the alarm output is active because of a test command, depressing the **OK** button will not reset the alarm output.

The following table illustrates the Error Messages, the problem or cause, and a recommended corrective action:

ERROR MESSAGE	CAUSE	CORRECTIVE ACTION
EtotRL	Total rollover.	None
EPULSE	Pulse out overflow.	Use different pulse scaler or lower totalizer decimal point
EE-ES	EEPROM reset to factory defaults.	Consult factory
E-RtE	Flow rate exceeds the flow rate display capability.	Reduce flow rate or use lower flow rate decimal point
EFL0	Flow rate exceeds the 20 mA flow rate setting.	Reduce flow rate or increase 20 mA flow rate setting
LG BAT	Low battery.	Replace battery(ies)

6-4 Analog Output Calibration

The 4-20 mA analog output has been accurately set to 20.000 mA by the factory. No adjustment is required.

The 4-20 mA output may be verified periodically by installing a digital milliamp meter in series with the analog output and simulating a full scale or over range flow rate.

This page intentionally left blank.

7. ASSEMBLY/DISASSEMBLY PROCEDURE

Follow the disassembly instruction below for accessing electronic terminal block, replacing the battery, or replacing the electronic PCB assembly.

Remove four screws with a Phillips head screwdriver and lift off the cover.



After the cover is removed, use a flathead screwdriver to remove four screws and washers from the panel.



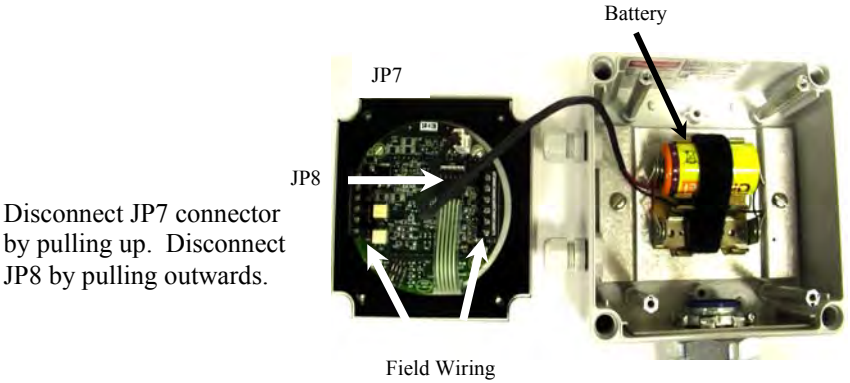

Remove four screws with a Flat-head screw driver. Two of the screws have washers and internal teeth washers. Finally, remove the PC board.

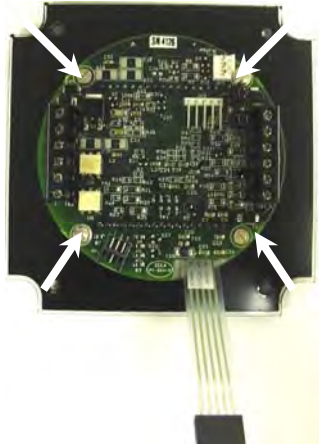

To re-assemble the unit, follow the instruction above in the reverse order.

8. RECOMMENDED SPARE PARTS LIST

The following table lists the recommended spare parts.

Hoffer Model/ Stock Numbers	Description
PCA170 800-0149	Electronic PCB assembly
100-2477	C-size battery

APPENDIX A – DEFAULT CONFIGURATION

Factory default configuration:

<i>FIELD</i>	<i>Value</i>
CL	No
DN	10000000
FC	0 (<i>Average</i>)
KD	3
AK	1.00
NP	20
F01	4999.981
F02	4999.982
F03	4999.983
F04	4999.984
F05	4999.985
F06	4999.986
F07	4999.987
F08	4999.988
F09	4999.989
F10	4999.990
F11	4999.991
F12	4999.992
F13	4999.993
F14	4999.994
F15	4999.995
F16	4999.996
F17	4999.997
F18	4999.998
F19	4999.999
F20	5000.000
K01	1.00
K02	1.00
K03	1.00
K04	1.00
K05	1.00
K06	1.00
K07	1.00
K08	1.00
K09	1.00
K10	1.00
K11	1.00
K12	1.00
K13	1.00
K14	1.00

<i>FIELD</i>	<i>Value</i>
K15	1.00
K16	1.00
K17	1.00
K18	1.00
K19	1.00
K20	1.00
CF	1.000
TU	100 (<i>GAL</i>)
TD	1
FM	1 (<i>MIN</i>)
RD	3
NB	01
LF	00000.000
AF	99.999
PS	0 (<i>OFF</i>)
FO	8
PA	1234
LK	No
UA	Off
AL	99999.981
ST	00000.000
OC	0 (<i>Rate</i>)
TP	No
AS	No

APPENDIX B - COMMUNICATIONS

Message Format And Timeout

Communication messages consist of a string of ASCII characters terminated by a carriage return character. The maximum message length coming to the HIT-2A-MIL is 20 characters, including the carriage return. The HIT-2A-MIL will transmit no more than 35 characters before transmitting a carriage return.

If a message longer than A 20 characters command is sent, the instrument responds with

"Command Sequence is Too Long! <NL>"

If an unrecognized or invalid command is sent, the instrument responds with

"Invalid Command! <NL>"

The sending unit RS232C serial port configuration must be configured as follows:

Baud rate:	2400
Data bits:	8
Parity:	none
Stop bits:	1
Handshaking:	none

The HIT-2A-MIL echoes all received messages and then transmits a response string terminated with a carriage return. If the sending unit takes longer than one minute to send a message, the HIT-2A-MIL aborts the message by clearing the receive buffer.

If the sending unit (PC or other such device) wishes to change a setting on the HIT-2A-MIL, the sending unit shall follow the command with an equal sign ("=") with the data following immediately after the equal sign. The carriage return terminates the message.

Any HIT-2A-MIL response that sends data back to the sending unit shall have an equal sign ("=") followed by the data. Space is allowed between the equal sign and the data on the return message, but the total message length is limited to 35 characters.

READ Example:

If the sending unit wishes to read the number of points that the HIT-2A-MIL has in the K factor table, the sending unit shall send

"NP<CR>"

The HIT-2A-MIL echoes the sent message, and responds with

"NUM PTS = 2<CR>"

WRITE Example:

If the sending unit wishes to change the number of points to 20 in the K factor table, the sending unit shall send

"NP=20<CR>"

The HIT-2A-MIL echoes the sent message and responds with

"NUM PTS = 20<CR>".

The HIT-2A-MIL checks the ranges for data and rejects writes that are not within the allowed range. If the sending unit sends data that is not within the allowed range, the HIT-2A-MIL echoes the sent message and responds with the value that is currently stored in the HIT-2A-MIL.

Example:

If the sending unit wishes to change the max sample time to 2000 from the previous setting of 10, the sending unit shall send

"NB=2000<CR>"

The HIT-2A-MIL echoes the sent message, and responds with

"MAX M TIME= 10<CR>".

Messages

Commands Supported By Communications Messages

Command	Description/Allowed Data/Response
CL ¹	Clear Total "0" to "99999999" "TOTAL = 0"
DN	Tag Number "0" to "99999999" "TAG NUM = (DATA)" The first three digits are the units code for total. Changing these digits will change the TU settings.
FC	Linearization "0" = Average K factor "1" = Linearization table "F C METHOD = AVG" for Average K factor or "F C METHOD = LIN" for Linearization table
KD	K Factor Decimal Point Location "0" for 0000000. "1" for 000000.0 and all K Factors are less than 999999.9, otherwise not allowed "2" for 000000.00 and all K Factors are less than 999999.99, otherwise not allowed "3" for 00000.000 and all K Factors are less than 99999.999, otherwise not allowed "K-FAC DECL= (DATA) "
AK	Average K Factor "0.001" to "99999.999" if KD = 3 "999999.99" if KD = 2 "9999999.9" if KD = 1 " 99999999" if KD = 0 "AVG KFAC =(DATA) "

Command	Description/Allowed Data/Response
NP	Number Points in the Table "2" to "20" "NUM PTS = (DATA)"
F##	Frequency 1-20 F01 has a range of "0.000" to the value of F02 minus 0.001; F20 has a range of the value from F19 plus 0.001 to "5000.000"; Frequencies F02 to F19 must be 0.001 greater than the previous frequency and 0.001 less than the next frequency. "FREQ ## = (DATA)" for F01 through F20. Data to fixed three decimal places.
K##	K-Factor 1-20 "K-FACT # = (DATA)" for K01 through K09. "K-FACT ## = (DATA)" for K10 through K20. DATA to decimal places as per KD command.
CF	Correction Factor "0.001" to "9999999.999" "CORR FACT = (DATA)"
TU	Total Units "100" for gallons "140" for liters "110" for cubic feet "150" for cubic meters "180" for barrels All other integer values from 0 and less than 999 will map to custom units "TOT UNITS = (DATA)" (DATA) shall be: "GAL" for gallons "LIT" for liters "FT3" for cubic feet "M3 " for cubic meters "BBL" for barrels "CUS" for custom These three numbers will be the same as the first three digits of the tag number. Changes to this menu shall cause the changes to the tag number.

Command	Description/Allowed Data/Response
TD	Total Decimal Point Location "0" for 00000000. "1" for 0000000.0. If UA set to Total and AL is greater than 9999999.9 it not allowed. "2" for 000000.00. If UA set to Total and AL is greater than 999999.99 it not allowed. "3" for 00000.000. If UA set to Total and AL is greater than 99999.999 it not allowed. "FLOW DEC L=(DATA)"
FM	Rate Units "0" for seconds "1" for minutes "2" for hours "3" for days "FLOW UNITS=(DATA)" <p style="margin-left: 40px;">(DATA) shall be:</p> <p style="margin-left: 80px;">"SEC" for seconds "MIN" for minutes "HR " for hours "DAY" for days</p>
RD	Rate Decimal Point Location "0" for 00000. "1" for 0000000.0 and AF (and AL if UA set to Rate) is less than 9999999.9, otherwise not allowed. "2" for 000000.00 and AF (and AL if UA set to Rate) is less than 999999.99, otherwise not allowed. "3" for 00000.000 and AF (and AL if UA set to Rate) is less than 99999.999, otherwise not allowed. "RATE DEC L=(DATA)"
NB	Max Sample Time "1" to "80" "MAX M TIME=(DATA)"
LF	Out Low "0.000" to a maximum value of the Out High setting "4mA FLOW =(DATA)"

Command	Description/Allowed Data/Response
AF	Out High Minimum is the Out Low Setting (LF) to a maximum of the following: "99999.999" if RD = 3 "999999.99" if RD = 2 "9999999.9" if RD = 1 " 99999999" if RD = 0 "20mA FLOW = (DATA) "
PS	Pulse Scale "0" for OFF "1" for 1 "10" for 10 "100" for 100 "PULS SCALE= (DATA) " (DATA) shall be: "OFF" for OFF "1" for 1 "10" for 10 "100" for 100
FO	Pulse Frequency "1" "2" "4" "8" "PULS FREQ = (DATA) "
PA	Password "0" to "9999" "PASS WORD = (DATA) "
LK	Lock Unit "0" for NO "1" for YES "LOCK UNIT = (DATA) " (DATA) shall be: "YES" for YES "NO" for NO

Command	Description/Allowed Data/Response
UA	Alarm Function "0" for OFF "1" for RATE "2" for TOTAL "ALARM FUNC= (DATA) " (DATA) shall be: "OFF" for OFF "RAT" for RATE "TOT" for TOTAL
AL	Alarm Out "0.001" to a maximum defined as follows: If UA is RATE: "99999.999" if RD = 3 "999999.99" if RD = 2 "9999999.9" if RD = 1 " 99999999" if RD = 0 If UA is Total or Off: "99999.999" if TD = 3 "999999.99" if TD = 2 "9999999.9" if TD = 1 " 99999999" if TD = 0 "ALARM OUT = (DATA) "
ST¹	Set Total "0.000" to a maximum defined as follows: "99999.999" if TD = 3 "999999.99" if TD = 2 "9999999.9" if TD = 1 " 99999999" if TD = 0 "TOTAL = (DATA) " (DATA) = "0" to the following maximums: "99999.999" if TD = 3 "999999.99" if TD = 2 "9999999.9" if TD = 1 " 99999999" if TD = 0

Command	Description/Allowed Data/Response
OC	<p>Current Out</p> <p>"0" - Current output follows rate. "1" - Current output set to 4mA. "2" - Current output set to 12mA. "3" - Current output set to 20mA.</p> <p>For "0", response = " Output equal to input." For "1", response = " Output is 4mA." For "2", response = " Output is 12mA." For "3", response = " Output is 20mA."</p>
PR	<p>Pulse Output Controlled By PS and FO</p> <p>" Pulse Output Released "</p> <p>The PS and FO menus shall control the pulse output. Used to terminate the TP command.</p>
TP	<p>Output 1Hz Test Frequency for Pulse Output</p> <p>" Test Pulse Output "</p> <p>Sets output to 1Hz, 50% duty cycle signal. This mode is for factory test.</p>
RA	<p>Release Alarm Output for Control According to Menu Settings</p> <p>" Alarm Released "</p> <p>Releases alarm output for control by the alarm output settings.</p>
AS	<p>Alarm Output Test</p> <p>"0" - Alarm output is set low. "1" - Alarm output is set high.</p> <p>For "0", response = " Alarm Active " For "1", response = " Alarm Released "</p> <p>After using the "AS" command, you must initiate a RA command to allow HIT-2A-MIL to return to normal operation.</p>

System Commands Supported by Communications Messages

System Command	Description/Response/Comments
OI	Output 4mA " Output is 4mA." Current output set to 4mA.
MO	Output 12mA " Output is 12mA." Current output set to 12mA.
OM	Output 20mA " Output is 20mA." Current output set to 20mA.
OF	Output = Rate (Input) " Output equal to input." Current output follows rate.
AA	Auto Data "F (DATA) R (DATA) T (DATA)" The response, not the echo, is sent every two seconds until it receives another message from the master. The (DATA) following the F denotes the frequency of the pulses to a precision of three places past the decimal, the (DATA) following the R denotes the rate to a precision of three places past the decimal, and the (DATA) following the T denotes the total to a precision of three places past the decimal.
DA	Dump All All of the responses in previous table. The HIT-2A-MIL gives all responses except for the CL command.
UI	Unit Identification "UNIT MODEL=HIT2A XX YY.ZZ" Model and software number for the unit. XX is the hardware revision number, YY.ZZ is the software revision where YY is the major software revision and ZZ is the minor software revision.

System Command	Description/Response/Comments
RT	Read Total "TOTAL = (DATA)" (DATA) = "0" to the following maximums: "99999.999" if TD = 3 "999999.99" if TD = 2 "9999999.9" if TD = 1 " 99999999" if TD = 0
RR	Read Rate "FLOW = (DATA)" (DATA) = "0" to the following maximums: "99999.999" if RD = 3 "999999.99" if RD = 2 "9999999.9" if RD = 1 " 99999999" if RD = 0
ST¹	Set Total See ST command above.
CN	Adjust 4mA output point "CN=# (DATA)" (DATA) is the integer value that the HIT-2A-MIL sends to the 4-20mA converter to output 4mA This parameter is passed to the HIT-2A-MIL to adjust the 4mA output point of the device. This value is used in production at the test step to calibrate the 4mA output point. "CN" will cause an Invalid Command response and absence of the # symbol will cause the HIT-2A-MIL to ignore the data.

System Command	Description/Response/Comments
<p>CM</p>	<p>Adjust 20mA output point "CM=# (DATA) "</p> <p>(DATA) is the integer value that the HIT-2A-MIL sends to the 4-20mA converter to output 20mA</p> <p>This parameter is passed to the HIT-2A-MIL to adjust the 20mA output point of the device. This value is used in production at the test step to calibrate the 20mA output point. "CM" will cause an Invalid Command response and absence of the # symbol will cause the HIT-2A-MIL to ignore the data.</p>
<p>SA</p>	<p>Set Alarm Output On " Alarm Active "</p> <p>Sets the alarm output active regardless of the settings.</p>
<p>US</p>	<p>Unit Status "UNIT STAT = <DATA> "</p> <p>Requests the status. The values for <DATA> with no or only one error present are:</p> <ul style="list-style-type: none"> " 0 " – No Errors present. " 128 " – EPULSE error (0x080) " 129 " – ETOTAL error (0x081) " 130 " – ERATE error (0x082) " 132 " – EFLOW error (0x084) " 129 " – EERES error (0x088) (EEPROM reset to factory defaults) <p>If multiple errors occur, the error codes are logically OR-ed. For example, if the unit has an ETOTAL and ERATE error occurring at the same time, the <DATA> = " 131 " (0x83).</p>
<p>CS</p>	<p>Clear Status " Status Cleared "</p> <p>Clears all errors.</p>

Note:

The CL and ST commands work as follows. The ST command shall store the present value of the total in Non-Volatile memory. This total in non-volatile memory shall be the initial total in the event that device power is removed and then re-applied. The CL command will clear the total in the device and the stored total in EEPROM but retain the present total in a volatile (RAM) memory location and keep it as the old total value. Removal of power from the unit causes this old total value to be lost. When the HIT-2A-MIL receives the ST<CR> from the PC, it shall echo back the old total value until the unit adds any value to the present total. If the HIT-2A-MIL receives a second CL command, the old total value shall be set to 0.

For example, if the present total is 123.45 and the HIT-2A-MIL receives CL<CR>, the present total is cleared (set to 0.0000), the total in EEPROM is cleared, and the old total value is 123.45. If the HIT-2A-MIL receives ST<CR>, the HIT-2A-MIL echoes with the total 123.45, the old total value. If the HIT-2A-MIL receives pulses to cause the present total to increment to 0.01 and then receives a ST<CR>, the HIT-2A-MIL will echo 0.01, or the present total.

The unit mimics this behavior on the display with the Clear Total Menu and the Set total menu. The reset total input (magnet or terminal input) acts the same as the receipt of a CL<CR> from the communications link.